

HHP

POWERFLUSHING PUMP

Instructions Manual
Use and Maintenance



HYDROCARE

CONTENTS

1. Description	page 4
2. Parts check list	page 4
3. Hose preparation	page 5
4. Heating system preparation	page 6
5. Vented systems	page 6
6. Site selection	page 6
7. Connection to the heating system	page 6
8. Pump	page 7
9. Radiator	page 7
10. Combination boiler systems	page 7
11. Flow and return connectors (boiler)	page 7
12. Across cold feed and expansion pipes	page 7
13. Initial flushing procedure	page 7
14. Additional advice relating to combination boiler systems	page 7
15. Flushing	page 8
16. Dumping the system water	page 8
17. Introducing chemicals to the system	page 9
18. Dumping	page 9
19. Acid cleaners	page 10
20. Finishing and cleaning procedure	page 10
21. And finally	page 10
22. Reinstating the system	page 10

Thank you for purchasing the **H+P POWERFLUSHING PUMP** from HYDROCARE...
Before using this equipment and to avoid personal injury, carefully read and understand these instructions. If there is anything you do not understand, **DO NOT** use this equipment, contact your supplier for advice.
Regular inspection, servicing and periodic maintenance will ensure many years of trouble free operation.

EC-DECLARATION OF CONFORMITY

We declare on our sole accountability that this product conforms to the standards and guidelines stated.



89/392 EEC; 91/368 EEC;
73/23 EEC; 89/336 EEC;
EN 50144.1

Please read and retain these directions for use. Do not throw them away! The warranty does not cover damage caused by incorrect use of the equipment! Subject to technical modifications.

1. DESCRIPTION

The H+P POWERFLUSHING PUMP is designed to power flush heating systems with minimal dismantling, by circulating water and flushing chemicals at high velocity, and then purging the dirty water from the system with a high flow of fresh, clean, water. Radiators may be individually flushed without removal from the system.

Your H+P POWERFLUSHING PUMP pump may be used with any commercially available flushing and descaling chemicals, except for strong acids or alkalis based products.

2. PARTS CHECK LIST

Carefully unpack the H+P POWERFLUSHING PUMP and check that all parts are present.

- H+P POWERFLUSHING PUMP Unit.
- 18 metre length of hose.
- 8 x 3/4" Female connections.
- 8 x Jubilee Clips.
- 2 x Plastic elbows M^{3/4}" – M^{3/4}".
- 2 x Brass F^{3/4}" – M1.1/2" connections.

Know your H+P POWERFLUSHING PUMP

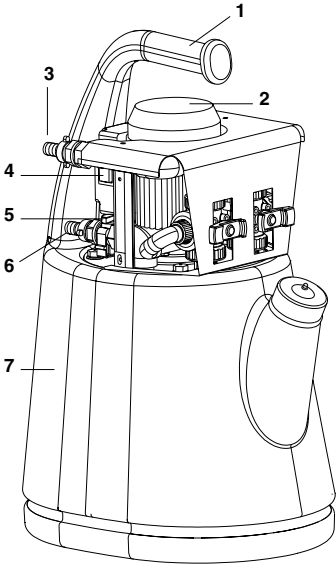

1. Transport handle
2. Motor
3. Flow/return
4. ON/OFF switch
5. Isolating valve
6. Fresh water connection
7. Reservoir

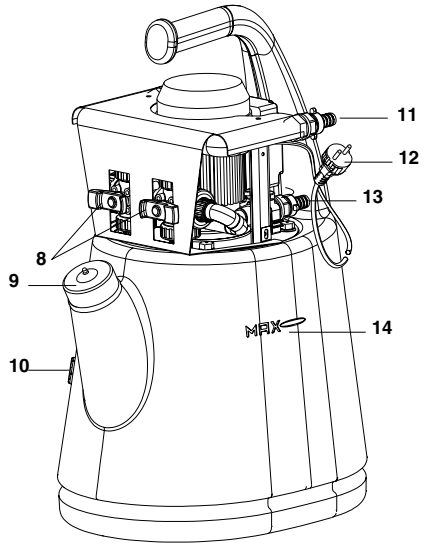

8. Dump valves
9. Filler Cap
10. Overflow connection
11. Flow/return
12. Power supply cable
13. Draw valve
14. Maximum fluid level

3. HOSE PREPARATION

You will need to prepare 5 lengths for the five connections on the H+P POWERFLUSHING PUMP, the lengths given are only a suggestion and can be altered to suit your needs.

Location	Length	No. of connectors
Fresh Water Inlet	4 m	2
Flow	3 m	2
Return	3 m	2
Dump	4 m	1
Overflow	4 m	1

Once cut, fit the connector / connectors to JDH end of the hose. Note, refer to the chart for hoses requiring a fitting on both ends. To fit a connector, firstly slide a hose clip over the hose. Press the connector into the hose almost fully in then tighten the hose clip until secure. Double check that the seal is still in place, see illustration.

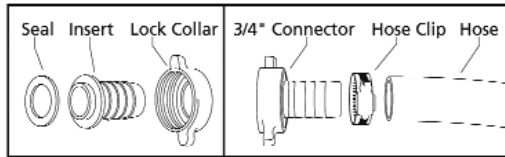

Now connect each hose to its respective connector, ensuring that a seal is present. Turn the connector clockwise until hand tight.

- 1 and 2. Flow & return hoses
- 3. Draw hose
- 4. Fresh water filler hose

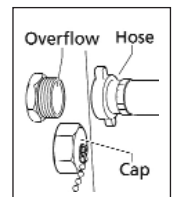
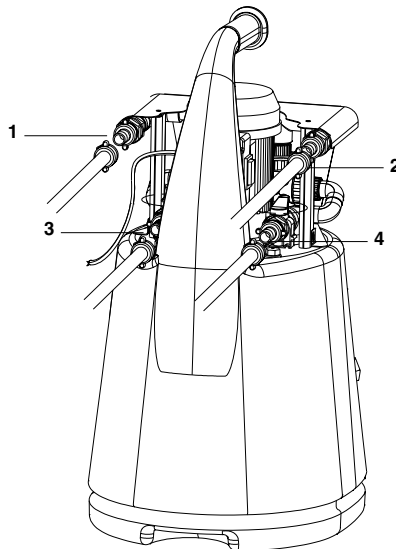

4. HEATING SYSTEM PREPARATION

Turn on the heating system and identify problem flow areas, cold radiators, or those with cold spots, etc, then switch the system off.

Make a note of each radiator's location and its condition.

Carefully record how many turns are required to shut off the radiator and lock shield valves. This will enable you to 'balance' the system quickly once you have finished.

Open all valves fully (both sides of the radiator).

Thermostatic radiator valves must be set to the fully open position. Remove the heads and check that the plunger pin moves freely.

Check that diverter or zone valves are in the fully open position, setting manually if necessary.

If an anti-gravity / check valve is present, this must be bypassed or bridged to allow the flow reversing action to be used. It may be possible to disassemble the anti-gravity valve, and remove internal components.

Tie up the ball cock or turn off the mains water supply by another means.

Drain enough water from the system to empty the F&E tank. This can be drained into the H+P POWERFLUSHING PUMP once it is connected.

5. VENTED SYSTEMS

You will need to either cap off, or loop together, the expansion and cold feed pipes to avoid filling and overflowing the expansion tank.

The F&E pipes may be capped with push fit end caps or a temporary compression fitting gate valve. Alternatively looping the feed and expansion pipes together will enable them to be flushed during the cleansing process.

NOTE: This will only be effective where the F&E pipes are not close coupled, or connected via an air separator.

The looping connection may be made with using an off cut of the H+P POWERFLUSHING PUMP hose, but should incorporate a valve in the loop to close the circuit when flushing individual radiators.

Any capping or looping must be removed after the flushing process.

6. SITE SELECTION

Position the unit in a room with a suitable drain point and a mains water supply. The cold water supply for a washing machine or dish-washing machine is a convenient source to consider.

Set both isolation valves to the closed position.

Run the drain hose and overflow hose to a suitable drain.

Connect the fill up hose to a suitable fresh water supply and open the supply valve. You will be able to control the water flow from the fresh water connector's isolator valve.

Fill the H+P POWERFLUSHING PUMP tank with water to a level between the Min and Max marker.

The normal precautions during work on any heating system should be taken, place a drip tray or waterproof groundsheet underneath the pump and surrounding area.

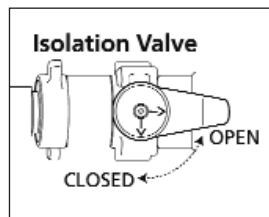

7. CONNECTION TO THE HEATING SYSTEM

Connect the flow and return hoses to the system at the selected point.

8. PUMP

Use the two 1.1/2" BSP female couplings to connect to the circulating pump's isolating valve.
Close the circulating pump isolating valves, remove the pump and fit the couplings. Only open the isolating valves once the H+P POWERFLUSHING PUMP is connected.

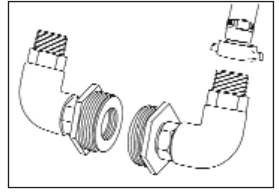

9. RADIATOR

Across the "tails" to a radiator (having drained and disconnected this radiator) using appropriate 1/2" or 3/4" BSP female adaptors to connect to the valve bodies.
The radiator valves should be closed to isolate the flushing pump from the system until power flushing is commenced.

10. COMBINATION BOILER SYSTEMS

The above connection method is generally used when power flushing a system with a combination boiler, when the system circulator pump is located in the boiler casing, and is difficult to access.

11. FLOW AND RETURN CONNECTORS (BOILER)

Across the flow and return connections at the boiler isolating the boiler itself.

12. ACROSS COLD FEED AND EXPANSION PIPES

By connecting across the cold feed and expansion pipes where accessible, but not adjacent to each other in the same pipe run. Remember to isolate the water supply to the F&E tank prior to fitting.

13. INITIAL FLUSHING PROCEDURE

Firstly, use the H+P POWERFLUSHING PUMP to loosen and mobilise loose silt and debris into the contaminated system water. This rids the system of as much debris and sludge at an early stage. The chemical can then work specifically to disturb, loosen, and dissolve more stubborn accumulations of debris.

14. ADDITIONAL ADVICE RELATING TO COMBINATION BOILER SYSTEMS

During power flushing, there is no circulation through the secondary heat exchanger of combination boilers.
To minimise the possibility of debris being pushed into the secondary heat exchanger circuit, close the boiler isolation valves during this first stage of the power flushing process.

15. FLUSHING

Remove the reservoir filler cap. It may be loosely replaced if the contents are ejected whilst flushing / descaling.

Close both dump valves.

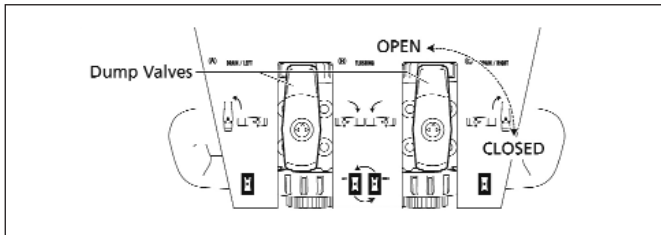

Plug the unit into a power supply protected by an RCD / ELCB and switch the supply ON.

The switch has three positions, clockwise (I), OFF and counter clockwise (II). Direction of flow is not of any great importance until you wish to 'dump' the systems water.

Switch the pump on and make sure that the water level in the reservoir remains at least 10 cm above the minimum mark, adding more water if necessary.

Check all hoses and their connections for leaks and repair before continuing.

Allow the pump to run for ten minutes, reversing the direction of flow regularly by moving the switch between setting I and II.

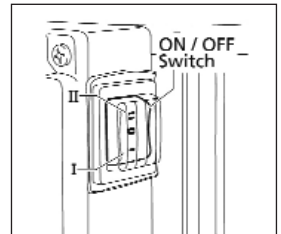

16. DUMPING THE SYSTEM WATER

When 'dumping', the water level in the unit's reservoir will fall by the same volume as is being dumped.

Switch the unit ON and turn the dump valves depending upon the direction of flow.

If the ON/OFF switch is in position I, open the right-hand dump valve and ensure that the left-hand dump valve remains closed. You can now open the drain valve fully.

If the ON/OFF switch is in position II, open the left-hand dump valve and ensure that the right-hand dump valve remains closed. You can now open the drain valve fully.

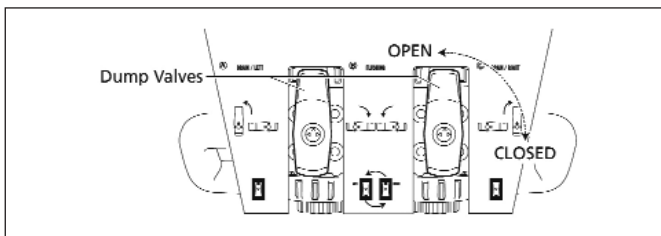

Turn the mains water supply ON and partially open the fresh water connector's isolator valve to allow fresh water to enter the reservoir at the same rate as water is exiting the dump hose. Make sure that the reservoir water level remains at least 10 cm above the minimum mark.

Continue dumping until the waste water runs relatively clear.

Re-opening the closed dump valve to restore full circulation through the Ro- Proflush pump and the system.

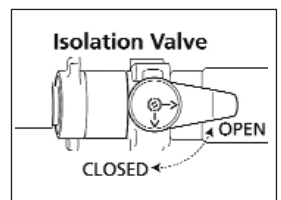

Close the water supply inlet valve once the level in the reservoir has stabilised between minimum and maximum markers.

Finally, bleed all radiators to expel any air build up.

17. INTRODUCING CHEMICALS TO THE SYSTEM

This next stage should only be performed after initial flushing and with the unit connected to the system.

Switch the H+P POWERFLUSHING PUMP unit ON so that water is recirculating through the heating system. Fully remove the reservoir filler cap and carefully pour a suitable power flush liquid into the reservoir.



WARNING !

Where the boiler is fitted and working.

With the unit still running, close the boiler on and allow the system water to reach a maximum temperature of 50oC before switching the boiler OFF.

Note that it is not imperative that the system water is heated.

With the unit still running, switch the boiler on and allow the system water to reach 50°C before switching the boiler OFF.

Operate the unit for 15 minutes, regularly reversing the direction of flow. Keep checking the connectors for signs of leakage.

With the unit running, close all radiator valves, this will allow the cylinder's coil to be thoroughly flushed remember to reverse the flow.

Close any diverter valves in favour of the radiator circuits ready to flush each radiator.

Working on all ground level radiators first, fully open both radiator valves on the nearest radiator.

Alternatively, start with the worst radiator first, so that the strongest concentration of chemical is directed at the worst areas of the system.

Flush the radiator, reversing the flow regularly until it is cleared.

Once cleared close both valves.

Open the valves on the next radiator, and repeat the procedure.

Work through the remaining radiators in turn, until every radiator in the system has been flushed individually.

18. DUMPING

Having flushed each radiator individually, then closed their respective valves, set the H+P POWERFLUSHING PUMP into dumping mode.

With the last radiators valves open, operate the unit until the water leaving the dump hose is completely clear. Alter the direction of flow and adjust the dump valves so that dumping is performed in both directions.

Once the dumped water from both directions is clear close both radiator valves.

Repeat this process on each individual radiator until all have been cleared.

Where the system has a hot water cylinder, open the diverter valves and flush the coil and dumping in both directions.

Finally, flush the boiler dumping in both directions.

19. ACID CLEANERS

Where an acidic cleaner has been used it must be neutralised to prevent long term corrosion.

Set the H+P POWERFLUSHING PUMP to normal re-circulation mode then open all radiator valves and diverter valves.

With the unit running, add 375gm of suitable neutralising crystals to the reservoir. If the water foams excessively, add a few drops of foam breaker.

Continue circulating in both directions for fifteen minutes, then set to dump mode and dump for at least ten minutes to clear all chemicals. Check the water exiting from the dump hose with pH paper. Continue dumping until the paper reads 7ph OR the same pH reading as the properties main water supply.

Set the H+P POWERFLUSHING PUMP to normal re-circulation mode.

20. FINISHING AND CLEANING PROCEDURE

The heating system has now been fully flushed and is full of fresh clean water. You should now introduce a suitable, good quality corrosion inhibitor.

Open the dump valve to reduce the water level in the reservoir to 6mm above the minimum line.

Set the H+P POWERFLUSHING PUMP to normal re-circulation mode, then with the unit running, add the corrosion inhibitor to the reservoir. Allow the chemical to circulate through the system for about 10 minutes, reversing direction occasionally.

21. AND FINALLY

Switch the pump OFF and unplug it from the power supply.

Disconnect all hoses from the H+P POWERFLUSHING PUMP and the system.

Empty the pumps reservoir of any remaining water. Note that if the system is vented, the residual water may be poured into a bucket and added to the F&E tank after this has been cleaned.

22. REINSTATING THE SYSTEM

Reconnect any removed radiator or disconnected boiler/ pump. Reset radiator balance valves to original settings.

Remove any temporary isolating valves or caps on the expansion and cold feed pipes, and restore non return valves to normal operation if necessary. The feed & expansion tank should be thoroughly cleaned, and disinfected before placing into service.

When its useful life is over, do not dipose or the machine into the domestic waste, please send it to auhorised places for recycling.



Please read and retain these directions for use. Do not throw them away! The warranty does not cover damage caused by incorrect use of the equipment! Subject to technical modifications.

23. WARRANTY TERMS AND AFTER-SALE ASSISTANCE CONDITIONS

HYDROCARE guarantee that the equipments sold are free from designing, manufacturing and material defects, under normal operating conditions and according to the directions contained in the instructions manual supplied with the equipment.

In compliance with the directive 1999/44/CE valid in the EEC countries, the warranty rights apply only to the purchaser. The warranty supplied by HYDROCARE leaves these rights unprejudiced.

HYDROCARE., placed in Unit 11, Capital Industrial Estate, Crabtree Manorway South, Belvedere Kent SA17 6BJ, guarantee the equipments against any conformity defects appearing within 24 (twenty-four) months from the purchase date, even when warranty operations have been carried out during this period, if only proved by a document.

The warranty covers all components of the equipment and provides for the repairing or, if necessary, the free replacement of those parts that, according to your Dealer, have conformity defects.

The warranty does not cover the aesthetic parts and the parts subject to wear and tear, nor does it cover all damages or failures whose cause is not due to the manufacturer, such as: transport, wrong installation or maintenance, tampering, sudden changes of electric voltage and/or hydraulic pressure, thunderbolts, corrosions, excess of humidity, accidental bumps or events beyond our control.

The warranty is valid only if the equipments have been installed, used and properly maintained according to all directions supplied by HYDROCARE in the instructions manual attached to the equipment.

Should any conformity defects of the product be found during the warranty period, the Customer shall notify the Dealer to agree upon the terms of repairing and/or replacing of the product.

The after-sale assistance service under warranty is always supplied by your Dealer.

Claims.

For claims, please contact your dealer.

